

UL  
 c E301099

SÉRIE LUXSTRUT 9100  
 FEUILLE D'INSTALLATION  
 LUXSTRUT 9100 SERIES  
 INSTALLATION SHEET

1. Installation

1. Appuyer et coller le ruban DEL (suivre les guides 10 mm ou 14 mm) sur le rail.

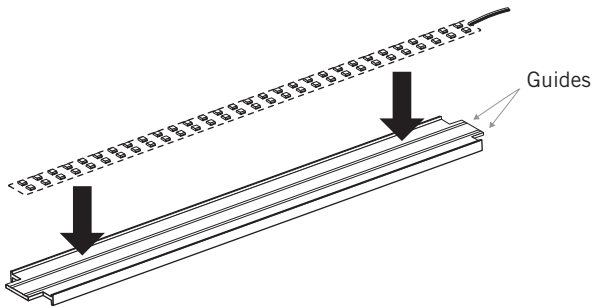

2. Glisser le rail à l'intérieur de la barre profilée.

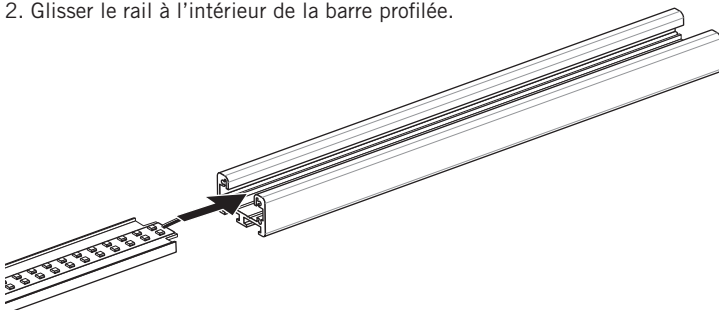

1. Installation

1. Press and glue the LED Strip Tape onto the rail (follow 10 mm or 14 mm guides).

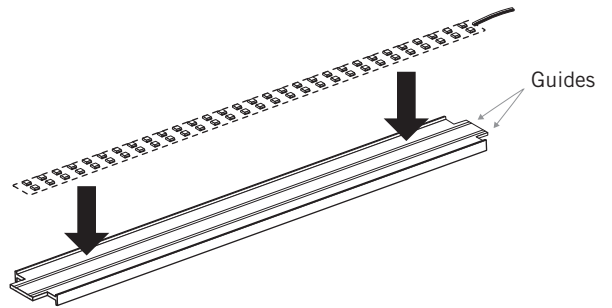

2. Slide the rail into the profiled bar.

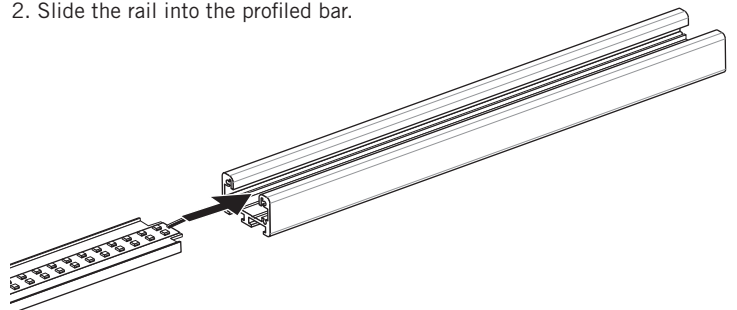

Safe, Fast and Easy to install with the ELED POWER  
 Installation simple et rapide avec le système de connexion  
 ELED POWER



## 1. Installation

3. Mettre la lentille en place.

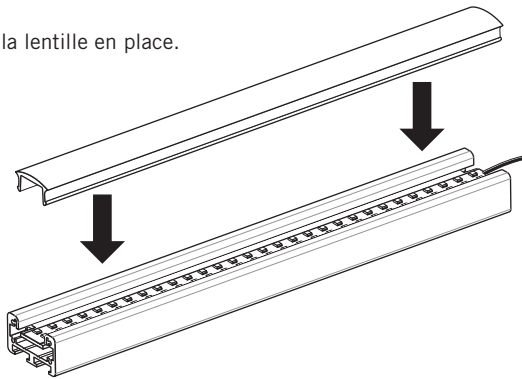

4. Glisser les fixations pour installation en surface (A) ou suspendue (B), puis reserrer les vis de fixation.

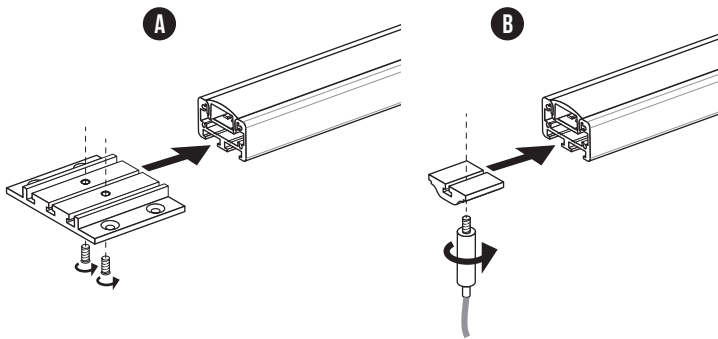

5. Glisser les embouts en place. Installer le luminaire à l'endroit choisi.

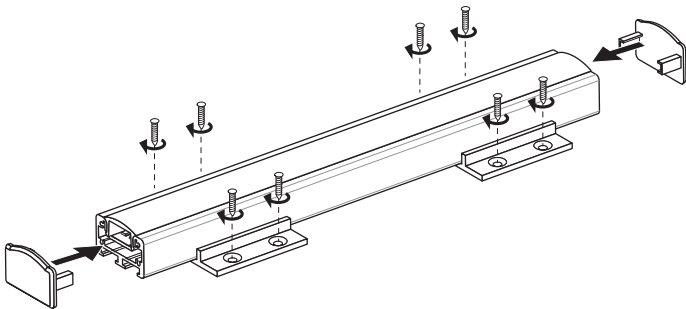

### Mise en garde

1. Utiliser seulement des composants Certifiées Classe 2 n'excédant pas 30VCC ou 15VAC lors d'une installation dans un endroit mouillé ou 60VCC ou 42.4V ca maximum lors d'une installation dans un endroit sec ou humide.
2. Ne pas dépasser 5 ampères pour respecter les normes classe 2.

CLASSE  
2

100W  
MAX

4 AMP MAX  
↓ 24V

5 AMP MAX  
↓ 12V

## 1. Installation

3. Clip the lens into place.

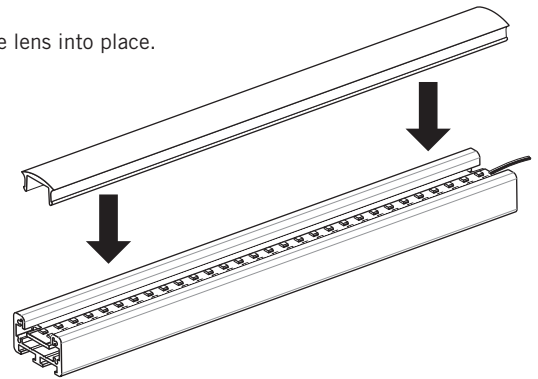

4. Slide in the brackets for surface mounting (A) or suspension (B), then tighten the mounting bolts.

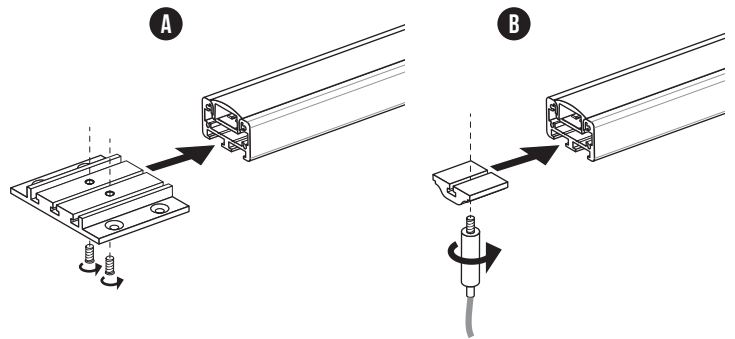

5. Slide the encaps into place. Install the light fixture at the chosen location.

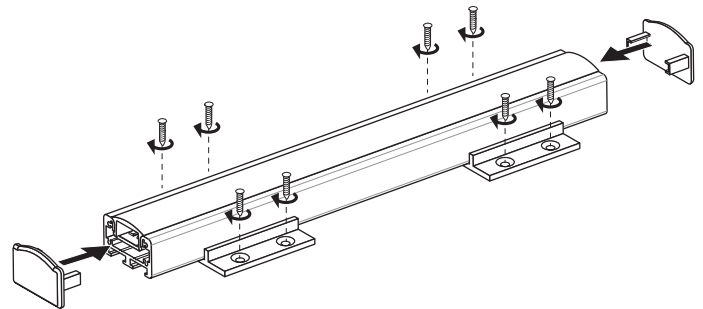

### Warning

1. Use only Class 2 rated components not exceeding 30VDC or 15VAC when installing the outline lighting in wet locations or 60VDC or 42.4V peak ac when installing the outline lighting in a dry or damp location.
2. Do not go over 5 amps to match class 2 requirements.

CLASS  
2

100W  
MAX

4 AMP MAX  
↓ 24V

5 AMP MAX  
↓ 12V